

# PreFilter System

Water Filtration systems for the food service industry.



**SELECTO SCIENTIFIC**  
INCORPORATED

Proud Member of:



**DO NOT USE** with water that is microbiologically unsafe or of unknown quality without adequate disinfection before or after the system.

# 1. Installation Precautions

The **Selecto Water** Treatment systems are carefully designed to reduce sediment. Prevent scaling and corrosion in your equipment.

Follow these instructions with care and we are certain that you will be satisfied with the unit and benefit from its low-cost operations.

## What to know prior to Installation

- ⚠ The **Selecto Water** Treatment systems are not to be used where water is microbiologically unsafe or with water of unknown quality without adequate disinfection before or after unit.
- ⚠ Do not install where line pressure is outside of 40 - 125 psi, or where temperature is lower than 40°F or exceeds 100°F.
- ⚠ Installation must comply with any existing state or local plumbing codes.
- ⚠ The unit(s) must be protected against freezing. Failure to do so may result in cracking of the filter and water leakage.
- ⚠ The **Selecto Water** Treatment system is designed for cold water line use only. Passing hot water through the system may seriously damage filter housing.
- ⚠ Filter must be in contact with water at all times.
- ⚠ Recommended pH range is 6 to 8.5.
- ⚠ Recommended inlet pressure 60 psi.
- ⚠ Tools needed: drill, screwdriver, tube cutters (if hard plumbing: lead free solder, heating device, and flux)

# 2. Installation

## Unpacking

- ⚠ Remove filter system from packaging and inspect for shipping damage. Notify shipping company immediately if damaged.
- ⚠ Carefully lift filter system, using proper lifting techniques (use your legs, not your back) from the box to inspect thoroughly.
- ⚠ Dispose of packing material, so as not to create a tripping hazard during installation.

## Positioning water filter

- ⚠ The water filter should be mounted upright on a horizontal surface without obstructions.
- ⚠ Locate a position that is close to the equipment it will be supplying water to, where it is out of the way of possible damage from day-to-day operations, and where it is accessible for cartridge changeout when needed. There should be a 6" minimum bottom clearance.

## 2. Installation

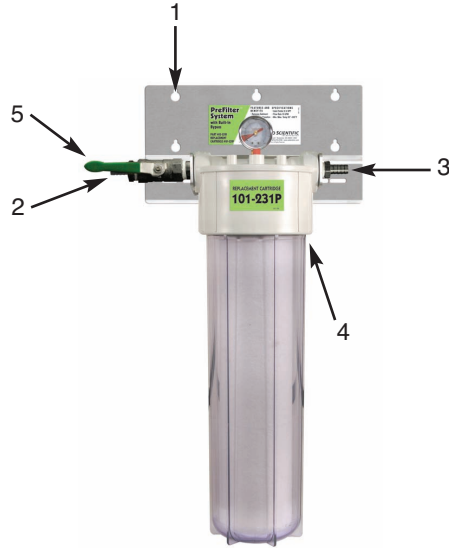

### Mounting

1. Measure backplane of filter system and mark hole locations on wall (See Item 1).

a. Ensure marks are level, then drills holes for anchors (if needed). Anchors must be properly matched, to allow for wet weight of filter system. Wet weight: **Prefilter: 32 lbs.**

b. Secure water filter to wall.

### Water Connections

2. Use appropriate 3/4" fittings and tubing to allow for a flow rate of 5 to 15 Gallons Per Minute (GPM) (See Item 2).

b. Connect water filter inlet to cold water supply. Use approved flexible beverage tubing where possible with correct sized tube clamps. If hard plumbing is necessary then use only lead free solder and protect filter housing from excessive heat.

c. If applicable: If unit was supplied with a three way ball valve, install on outlet of water filter using supplied instructions. Use supplied fittings only to allow for proper water flow.

3. From outlet of water filter use no less than 3/4" ID tubing to all specified equipment. It is only permissible to decrease line size when multiple lines are being used (See Item 3).

\* Teeing the tubing should be done appropriately, for example 3/4" x 3/4" x 3/4". This is only to be done at equipment location if line is to be used for other equipment.

### Initializing Water Filter

4. Check to see if O-Ring is lightly lubricated. Do this by unscrewing the bottom bowls and looking on top of bowl. The O-Ring is the black rubber looking material. Re-attach bowl and hand tighten only for proper sealing (See Item 4).

5. Turn inlet ball valve to the on position slowly allowing water to fill filter system (See Item 5).

6. System is now operational. Go back and check every connection for possible leaks and fix where needed.

## 3. Maintenance

### Cartridge Change out Schedule (If Gauge is Provided)

1. When the line pressure downstream of the filter housing drops to 30 psi or below during system operation, the cartridge(s) needs to be replaced. Occasional dips below 30 psi and back are normal.
2. Attach laminated cartridge change out procedures to wall next to filter system at a level that is easy for viewing.
3. For Ordering information for cartridge replacements see Specifications.



## 4. Specifications

### PreFilter

System Part: #02-231  
Replacement Cartridge: Pre-Filter #101-231P

#### SPECIFICATIONS:

- Rated Capacity: Change as Needed
- Flow Rate: 15 gpm
- Recommended Operating Pressure: 80–125 psi.
- Min/Max Temperature: 40°–100° F
- Inlet/Outlet Size: 3/4 Inch Barbed Fittings
- Shipping Weight: 25 lbs.
- Wet Weight: 32 lbs.
- System Dimensions (W/D/H): 17/9/22”
- 4” Service Clearance from Bottom of Cartridge

#### APPLICATIONS:

Ice or other equipment requiring Pre-Filtration

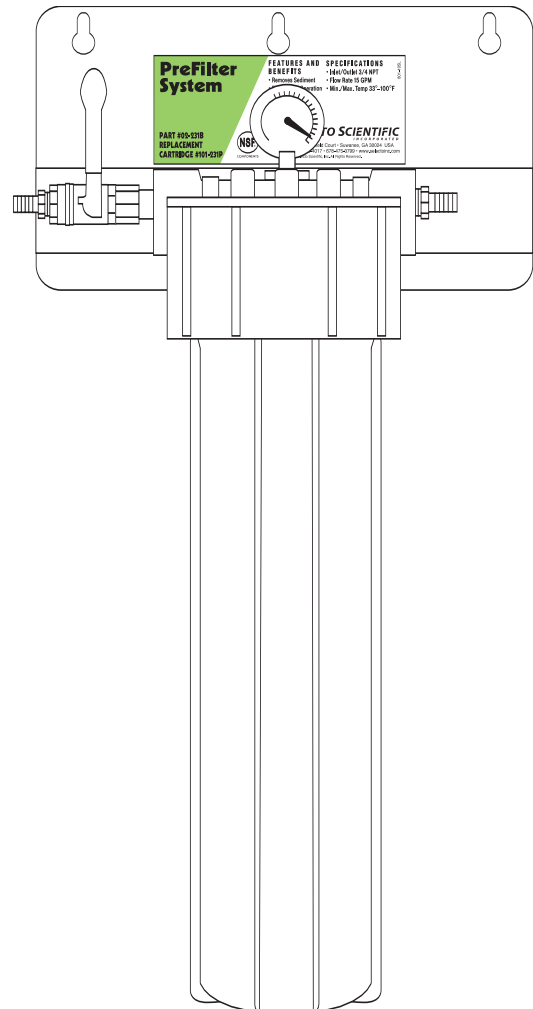

# 5. Warranty

## CLAIMS POLICY

All claims, whether concealed or not, are the responsibility of the account. Any carton damage or shortages should be noted on the bill of lading at the time of receipt of the shipment, in accordance with I.C.C. Regulations. If the concealed damage or loss is noted by the account while unpacking the shipment, the carrier should be notified immediately, per I.C.C. Regulations.

SELECTO must be notified, in writing, including a copy of the carrier's claim form, of any damage or loss claims within 45 days. Failure to so notify SELECTO releases SELECTO from any liability.

## WARRANTY POLICY

SELECTO warrants the Product to be free of defects in material and workmanship. Any defects will be remedied by SELECTO in the manner provided below.

The Plastic Housing(s) on the Product carry a five (5) year unconditional warranty for parts. Any modular changes or abuse voids warranty. Warranty together with any and all warranties implied by law, shall be limited to a duration of one (1) year on all other parts and components.

This Warranty does not apply to defects or damage due to abuse, neglect, misuse, accident, alteration, freezing, fire or damage not caused by SELECTO. In no event will SELECTO be liable for incidental or consequential damages from a defective unit or improper installation. **CHECK ALL CONNECTIONS FOR LEAKS BEFORE OPERATING THE UNIT.**

SELECTO's responsibility under this warranty shall be to repair, at its expense, any Product that is actually defective, or otherwise in violation of this Warranty. If SELECTO for any reason cannot repair a Product covered hereby within three (3) weeks after receipt of the defective unit, then SELECTO's responsibility shall be at its option, either to replace the defective Product with a comparable new unit at no charge, or to refund the full purchase price. SELECTO's obligations of repair, replacement, or refund are conditional upon return of the defective Product to SELECTO. If any Product covered hereby is actually defective within the terms of this warranty, then SELECTO will bear all the reasonable and proper shipping or mailing charges incurred in the return of the Product as set forth herein. If the Product proves not to be defective within the terms of this Warranty, then all costs and expenses in connection with processing of the consumer's claim hereunder shall be borne by the consumer.

**THIS WARRANTY GIVES YOU SPECIFIC LEGAL RIGHTS, AND YOU MAY ALSO HAVE OTHER RIGHTS, WHICH VARY FROM STATE TO STATE. WARRANTY IS VALID ONLY IN THE CONTINENTAL UNITED STATES.**

## RETURN POLICY

All returns, whether defective or not, must be pre-approved by SELECTO, and accompanied by a Selecto Scientific, pre-approved valid, return goods number clearly marked on the outside of the shipping container. All returned goods must be shipped prepaid to SELECTO from point of origin. Returns not shipped prepaid or missing a returned goods authorization number, will be refused.

**0 - 30 Days: 15% restocking fee**  
**31 - 60 Days: 25% restocking fee**  
**61 - 90 Days: 35% restocking fee**  
**After 90 Days No Returns Accepted**

3980 Lakefield Court • Suwanee, GA 30024  
Phone: 678.475.0799 • 800.635.4017 • Fax: 678.475.1595  
Selecto Scientific is a subsidiary of Selecto, Inc.  
[www.selectoinc.com](http://www.selectoinc.com)



**SELECTO SCIENTIFIC**  
INCORPORATED